

Description

Model 11R * is a Piston type self contained pumping element supplied with its Suction valve, Delivery valve and a spring loaded piston as a single unit. It is basically meant for supplying small volume of lubricating oil under high pressure.

For its working, the element must remain submerged in the oil all the time while pumping.

Reciprocating motion of the piston gives pumping action. The motion is assumed to be given by a bearing.

Radially arranging a number of such elements around a bearing, which is mounted eccentrically on a rotating shaft and connecting all delivery port of the elements together will create a pump giving a continuous oil flow. Odd number of elements connected in such a manner will give smoother flow than even number.

There are three types of pumping elements, each having different displacement and pressure rating.

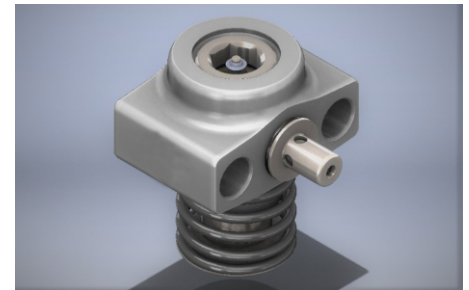

Technical specifications

Type	:	Reciprocating Spring loaded piston, Oli immersed.
Mounting Standard	:	Factory standard.
Operating Speed range	:	300 to 2000 strokes/min.
Hydraulic medium	:	Mineral oil.
Oil Temperature range	:	-20°C to + 80°C.
Viscosity range	:	10 cSt to 100 cSt.
Fluid cleanliness required	:	ISO 4406 20/18/15 or better.
Flow and pressure rating	:	Refer Table - 1

Hydraulic symbol

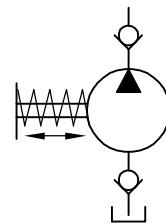
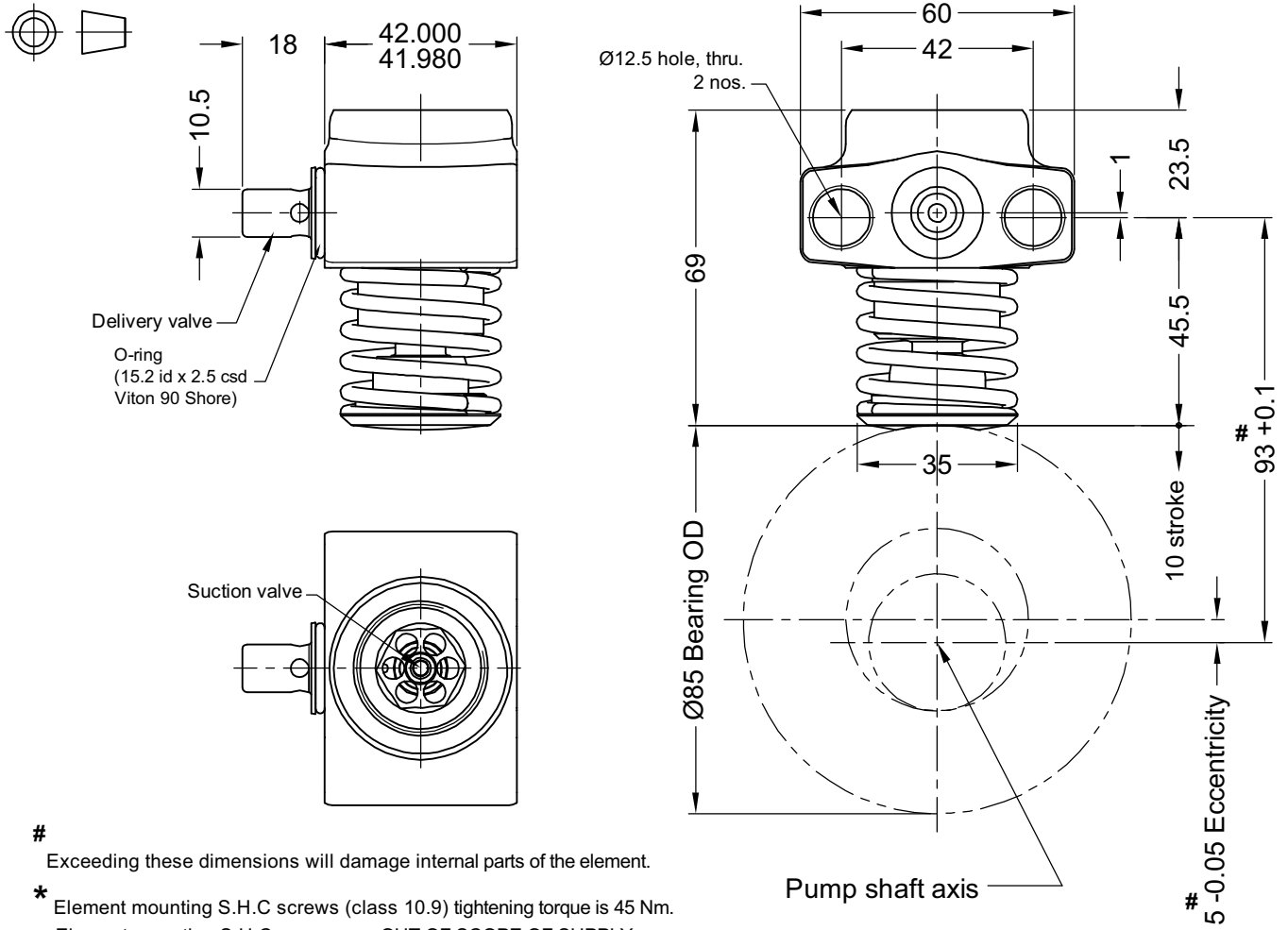

Table - 1

Model	Geometrical displacement with 10 mm stroke cm ³ /stroke	Max. operating pressure (bar)	Expected Delivery flow (l/min)		Force required to operate piston at rated pressure (N)	Mass (kg)
			1450 stroke/min.	2850 stroke/min.		
11R A	1.54	400	2.1	4.1	6160	0.4
11R B	2.01	315	2.7	5.2	6460	
11R C	2.54	250	3.5	6.8	6370	



- # Exceeding these dimensions will damage internal parts of the element.
- * Element mounting S.H.C screws (class 10.9) tightening torque is 45 Nm.
Element mounting S.H.C screws are OUT OF SCOPE OF SUPPLY.

Ordering code

11R A -03

Pumping element

Design code subjected to change. Installation dimensions remain same for design code 01 thru 09.

Type of element		
Flow and pressure rating		
Operating Pressure in bar	Geometrical displacement with 10 mm stroke cm ³ /stroke	Code no.
400	1.54	A
315	2.01	B
250	2.54	C

Element mounting details

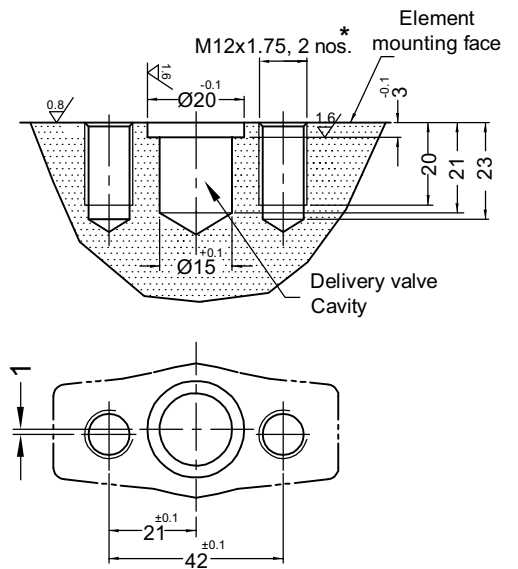

All rights reserved.
Subject to change without notice.
Due to continuous improvement in the design of the product, the actual product supplied may look different than shown above.
For critical applications, please ask for certified installation drawing.