

Description

Pumps model 1R3** are small , low weight , rugged oil immersed type Radial Piston Pumps. These pumps are valve controlled and there is no restriction on direction of rotation of the pump.

These are available with 7 displacements and 7 pressure ratings.

These pumps give fixed output per revolution of the shaft.



Section

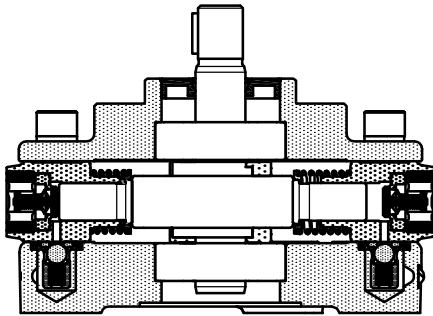

Hydraulic symbol

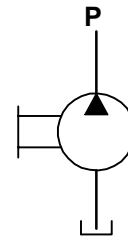

Technical specifications

Designation	:	1R is a basic radial piston pump group.
Design	:	Radial piston, valve controlled.
No. of elements	:	3.
Mounting	:	Face mounting.
Interface	:	Factory standard.
Direction of rotation	:	No restriction on directions of rotation
Connection	:	Suction port - Sucks oil directly from tank no suction port is provided. Delivery (port P) - G1/4 female.
Speed range	:	300 to 2000 r/min.
Flow and Pressure	:	Refer T able no.1
Hydraulic medium	:	Mineral oil.
Temperature range	:	-20°C to + 80°C.
Viscosity range	:	10 cSt to 100 cSt.
Fluid cleanliness required	:	ISO 4406 20/18/15 or better.
Mass	:	5.29 Kg.

Unit dimensions

Dimensions in mm.

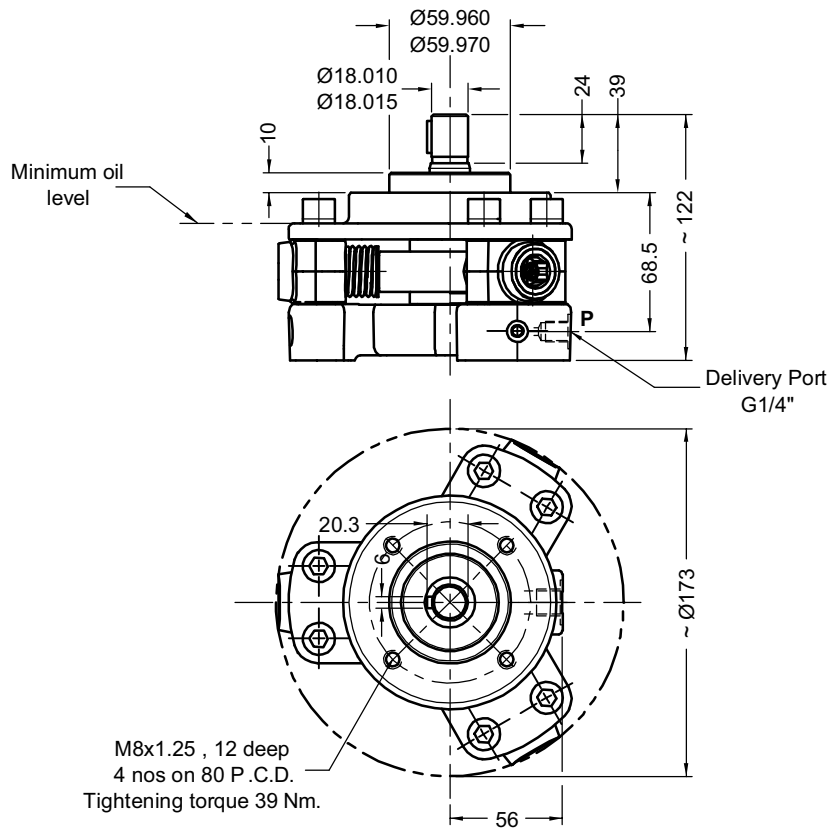
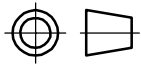

Performance Table no. 1

No. and type of Elements	Geometrical displacement in cm ³ /r	Pump output in l/min at 1450 r/min	Maximum operating pressure	Pressure in bar														
				50	100	150	200	250	300	350	400	450	500	550	600	650	700	
	cm ³ /r	l/min.	bar	Power required to drive the pump in kW														
3 Z	0.69	0.9	700	0.10	0.19	0.29	0.39	0.48	0.58	0.68	0.77	0.87	0.96	1.06	1.16	1.25	1.35	
3 A	1.20	1.6	550	0.17	0.34	0.51	0.69	0.86	1.03	1.20	1.37	1.54	1.71	1.89				
3 B	1.89	2.6	450	0.27	0.54	0.80	1.07	1.34	1.61	1.88	2.14	2.41						
3 C	2.70	3.7	350	0.39	0.77	1.16	1.54	1.93	2.32	2.70								
3 D	3.18	4.3	300	0.45	0.91	1.36	1.81	2.26	2.72									
3 E	3.69	5.0	250	0.53	1.05	1.58	2.10	2.63										
3 F	4.23	5.8	200	0.60	1.21	1.81	2.41											

1kW = 1.3410 hp

Ordering code

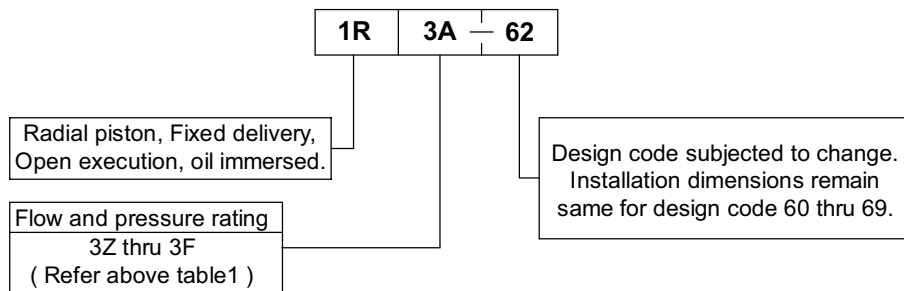

Note : For Bell housing refer Data sheet no. D 09035.